

# Quiz: Name That Machine Guard



## **MACHINE GUARDS, 101**

Before you start the Quiz, here's a quick overview of the basic types of machine guards:

### **A. Guards**

Guards are physical barriers that block workers' access to the danger area. There are 4 basic kinds of guards:

1. Fixed guards that are a permanent part of the machine;
2. Adjustable guards that allow for flexibility in accommodating different sizes of stock;
3. Interlocked guards that automatically shut off or stop the machine when tripping mechanism is activated until the guard is put back in place; and
4. Self-adjusting guards in which the size of the opening in the barrier adjusts to accommodate the stock, e.g., enlarges to allow larger stock to enter.

### **B. Devices**

Devices automatically stop the machine. The 3 basic types:

1. Presence sensing devices that stop the machine's operating cycle when a light field is broken, e.g., a worker sticks his hand in the danger zone;
2. Pullback devices that use a series of cables attached to the operator's hands, wrists, and/or arms; and
3. Safety controls like tripwire cable, and two-hand control.

## NAME THAT MACHINE GUARD

**Instructions:** Name the type of machine guard pictured:

1. This is a/an:

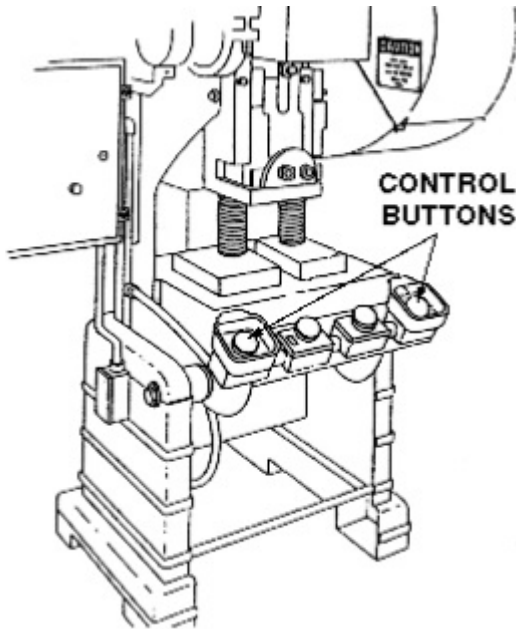

- A. Fixed guard
- B. Two-hand control
- C. Adjustable guard
- D. Presence sensing device

ANSWER:

B. Two-hand control

\*\*\*\*\*

2. This is a/an:

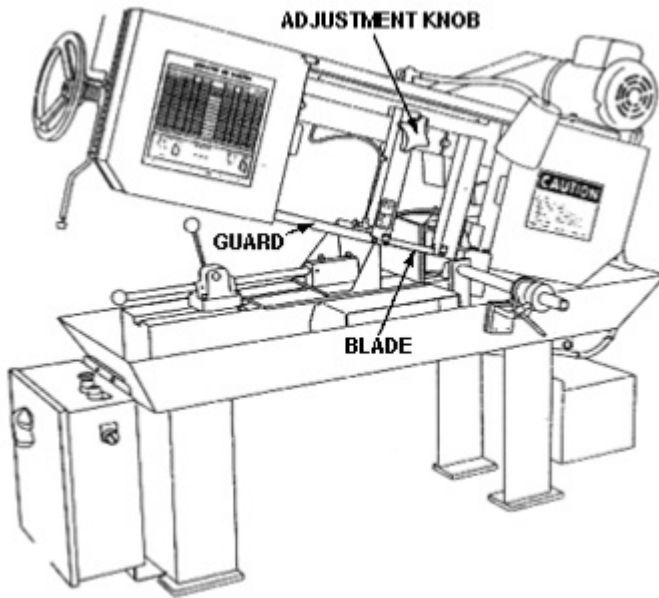

- A. Fixed guard
- B. Two-hand control
- C. Adjustable guard
- D. Presence sensing device

ANSWER:

C. Adjustable guard

\*\*\*\*\*

3. These are:

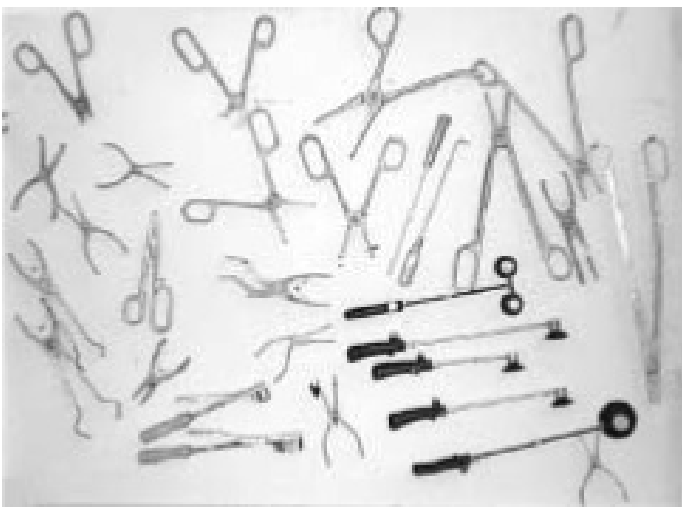

- A. Hand feeding tools
- B. Lockout devices
- C. Tagout devices

D. Barrier guards

ANSWER:

A. Hand feeding tools

\*\*\*\*\*

4. This is a/an:

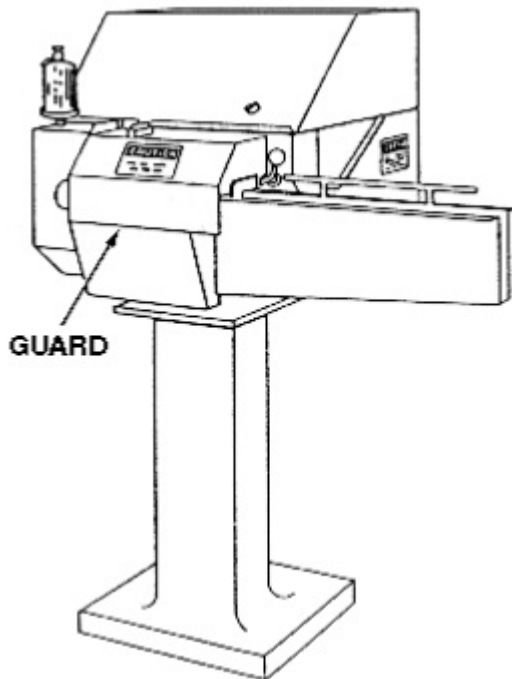

- A. Fixed guard
- B. Interlocked guard
- C. Adjustable guard
- D. Self-adjusting guard

ANSWER:

B. Interlocked guard

\*\*\*\*\*

5. These devices are:

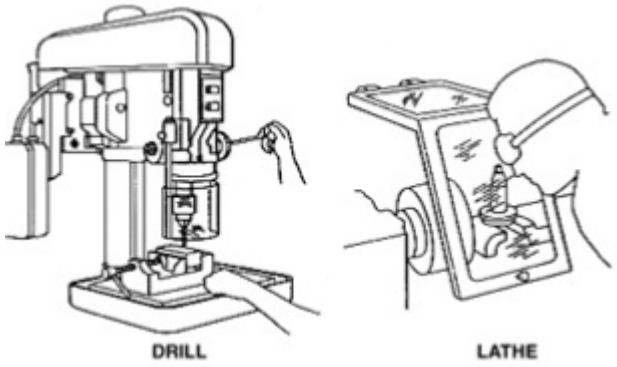

- A. Presence sensing devices
- B. Hand feeding tools
- C. Gates
- D. Protective shields

ANSWER:

- D. Protective Shields

\*\*\*\*\*

6. This is a/an:

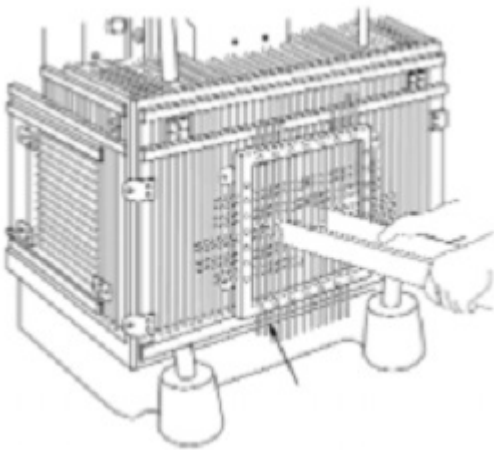

- A. Self-adjusting barrier guard
- B. Fixed guard
- C. Interlocked guard
- D. Location guard

ANSWER:

- A. Self-adjusting barrier guard

\*\*\*\*\*

7. This is a/an:

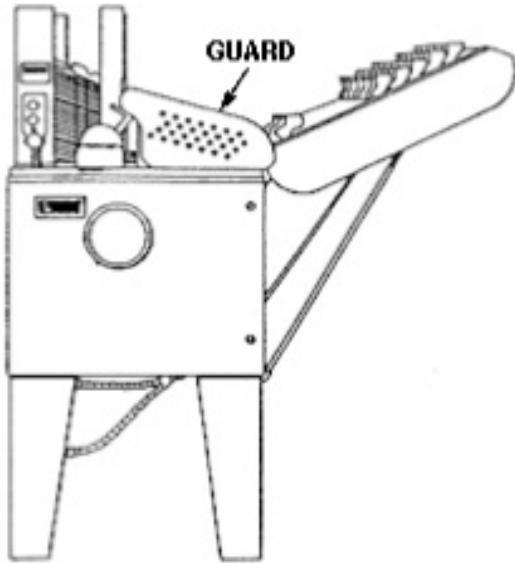

- A. Self-adjusting barrier guard
- B. Fixed guard
- C. Interlocked guard
- D. Location guard

ANSWER:

- B. Fixed guard

\*\*\*\*\*

8. This device is a:

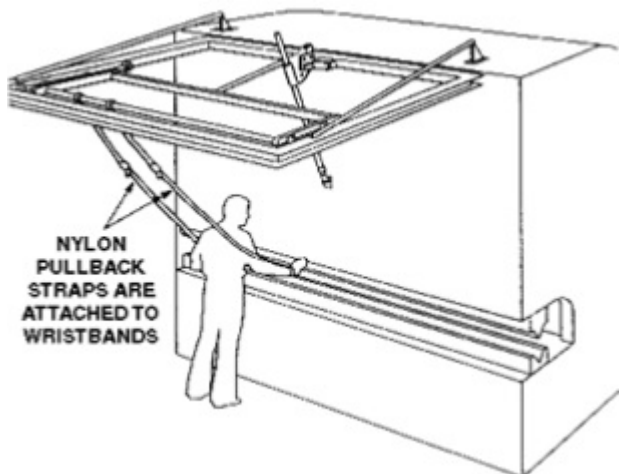

- A. Presence-sensing device
- B. Restraint device
- C. Pullback device
- D. Lockout device

ANSWER:

C. Pullback Device

\*\*\*\*\*

9. This device is a:

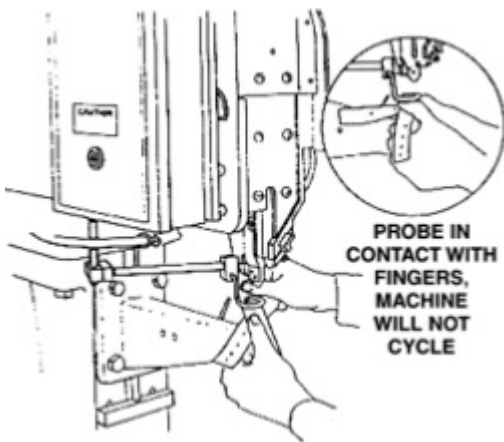

- A. Presence-sensing device
- B. Restraint device
- C. Pullback device
- D. Lockout device

ANSWER:

A. Presence-sensing device

\*\*\*\*\*

10. This guarding method is a:

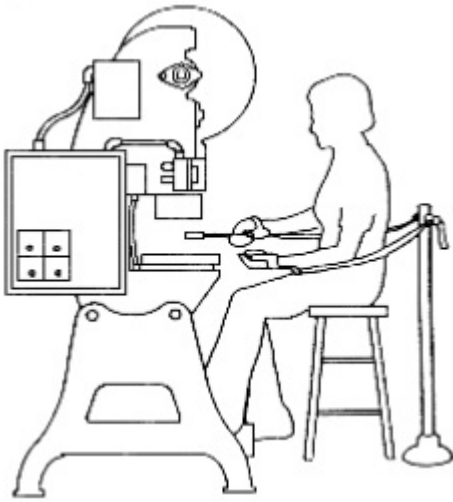

- A. Pullback device
- B. Protective shield
- C. Presence-sensing device
- D. Restraint

ANSWER:

D. Restraint

### **GRADE YOURSELF**

How did you do'

- **9 -10 right:** You know your machine guards
- **8 right:** Just beneath elite
- **7 right:** Better than average
- **6 right:** Passing
- **5 or less right:** 'Better brush up on your knowledge of machine guards